

2



1

B

SALES DRAWING

1/2-20 UNF - 2B ∇ .75

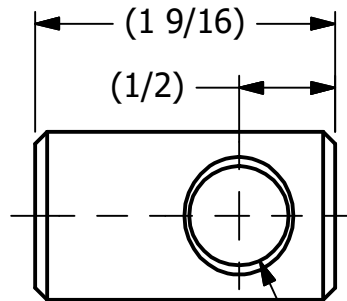
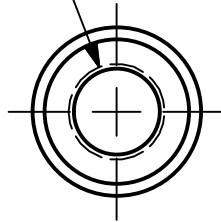

(Ø17/32)

(Ø7/8)

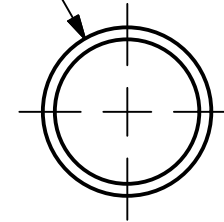

B

SALES DRAWING



ISOMETRIC VIEW

A

B	WEB	2/18/20	202010190853	WEB
REV	BY	DATE	REF #	PUB

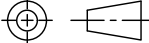
<small>UNLESS OTHERWISE SPECIFIED DIMENSIONAL TOLERANCES</small> FRACTIONAL: ±1/16 X.XX: ±.03 X.XXX: ±.015 ANGULAR: ±1° DEBURR ALL SHARP EDGES. ALL MACHINED SURFACES TO HAVE A 125 RMS FINISH UNLESS NOTED OTHERWISE. THIRD ANGLE PROJECTION 	DRAWN BY:	ACC
	CHECKED BY:	
	PROTOTYPE DATE:	4/26/2004
	APPROVED FOR PRODUCTION BY:	ACC
	PRODUCTION DATE:	9/7/2005
	SIZE:	A
DRAWING #:	19161	

 SALCO PRODUCTS, INC.		
PART NAME: LATCH PIN 1/2"		
MATERIAL: CARBON STEEL		
PROJECT #: 010427B	SHEET #: 1 OF 1	SCALE: 1 : 1
PART #: CLLPCZK		

A

2



1